

Distributed Synthesis Using Accelerated ADMM

Mohamadreza Ahmadi, Murat Cubuktepe, Ufuk Topcu, and Takashi Tanaka

Abstract—We propose a convex distributed optimization algorithm for synthesizing robust controllers for large-scale continuous time systems subject to exogenous disturbances. Given a large scale system, instead of solving the larger centralized synthesis task, we decompose the problem into a set of smaller synthesis problems for the local subsystems with a given interconnection topology. Hence, the synthesis problem is constrained to the sparsity pattern dictated by the interconnection topology. To this end, for each subsystem, we solve a local dissipation inequality and then check a small-gain like condition for the overall system. To minimize the effect of disturbances, we consider the H_∞ synthesis problems. We instantiate the distributed synthesis method using accelerated alternating direction method of multipliers (ADMM) with convergence rate $O(\frac{1}{k^2})$ with k being the number of iterations.

I. INTRODUCTION

Large scale systems are ubiquitous in nature and engineering. Examples of such systems run the gamut of biochemical networks [1] to smart grids [2]. The synthesis of control laws for large scale systems, however, is fettered by several challenges, despite the availability of well-known solutions to the LQR, H_2 , and H_∞ synthesis problem for linear systems [3].

Conventional feedback synthesis techniques are implemented in a centralized manner and often lead to controller gains that require dense interconnection topology. Such controllers require full communication between the subsystems that may not be practical. Therefore, significant research has been carried out in the literature to synthesize controllers with a given sparsity pattern. In general, the linear synthesis problem subject to a given sparsity pattern in the controller is NP-hard [4]. However, explicit solutions for special structures [5], [6], [7], convex relaxations [8], [9] and sub-optimal non-convex methods [10], [11] were proposed in the literature.

Furthermore, the computational cost of synthesizing centralized controllers become prohibitive for large scale systems. In the analysis domain, several attempts have been made to decompose the centralized analysis problem using dissipativity theory based on the notion that if the subsystems of an interconnected large scale system satisfy some dissipativity property, the overall interconnected system satisfies some stability or input-output property [12]. At the expense of some degree of conservatism, [13], [14] propose methods for analyzing large-scale dynamical systems by

decomposing them into coupled smaller subsystems that are significantly simpler from a computational perspective. Furthermore, distributed optimization techniques can be used to carry out the computations in parallel. In [15], it was demonstrated that one can study the stability of a large scale system by checking a number of dissipation inequalities for smaller local subsystems and then verifying a global gain condition, where the dual decomposition technique was used. Reference [16] gives a decompositional dissipativity analysis methodology for a large scale system based on ADMM.

Distributed optimization methods such as ADMM [17] are used to solve large-scale convex optimization problems by decomposing them into a set of smaller problems. These methods are most useful when interior-point methods do not scale well due to solving of a large linear system on the order of number of variables. However, these algorithms can be very slow to converge to high accuracy, unlike interior-point methods, where high accuracy can be attained in a reasonable amount of iterations. To attain faster convergence to high accuracy, *accelerated* versions of first order methods have been proposed in the literature [18], [19], [20], [21], [22]. These methods achieve $O(\frac{1}{k^2})$ convergence rate after k iterations, which is shown to be indeed optimal for a first order method [23]. The main drawback of these approaches is, they usually require the objective function to be differentiable, which disallows constraints in the optimization problem.

In this paper, we consider large-scale systems with a given interconnection topology. The interconnection topology of the system dictates a sparsity pattern to the global controller. Given this controller structure, we tackle the global synthesis problem by synthesizing local controllers such that some global system property, namely, stability or H_∞ performance is guaranteed. To this end, we use a set of local dissipation inequalities and adopt a block-diagonal global Lyapunov function structure. This decomposes the global synthesis problem into a number of smaller ones for local subsystems. Moreover, for large scale problems, we provide a computational formulation based on accelerated ADMM. We use a smoothing approach [24], [25] to achieve a faster convergence rate than the conventional ADMM. Specifically, when the objective function is strongly convex, the ADMM algorithm can be modified with an extra acceleration step to attain $O(\frac{1}{k^2})$ convergence rate [26]. We show the applicability of our approach in numerical experiments.

The rest of the paper is organized as follows. The next section presents the problem formulation and some preliminary results. In Section III, we describe the distributed stabilizing and H_∞ synthesis method based on dissipativity theory. In Section IV, we bring forward the computational

M. Ahmadi, M. Cubuktepe, U. Topcu and T. Tanaka are with the Department of Aerospace Engineering and Engineering Mechanics, and the Institute for Computational Engineering and Sciences (ICES), University of Texas at Austin, 201 E 24th St, Austin, TX 78712. e-mail: ({mrahmadi, mcubuktepe, utopcu, ttanaka}@utexas.edu).

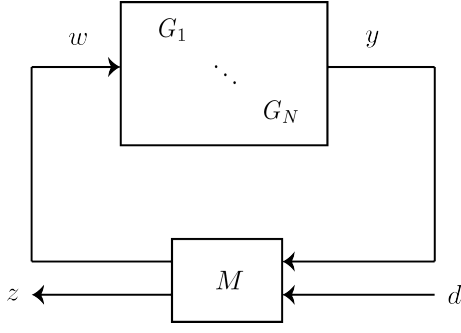

Fig. 1: Interconnected system with input d and output z .

formulation based on accelerated ADMM. Two examples are given in Section V to illustrate the proposed method. Finally, Section VI concludes the paper and provides directions for future research.

Notation: The notations employed in this paper are relatively straightforward. $\mathbb{R}_{\geq 0}$ denotes the set $[0, \infty)$. $\|\cdot\|$ denotes the Euclidean vector norm on Q and $\langle \cdot \rangle$ the inner product. We denote the set of $n \times n$ real symmetric matrices as \mathbb{S}^n . For a matrix $A \in \mathbb{R}^{m \times n}$, A^\dagger denotes the pseudo-inverse of A . Note that the pseudo-inverse of A always exists and is unique [27]. For a function $f : A \rightarrow B$, $f \in L^p(A, B)$, $1 \leq p < \infty$, implies that $(\int_A |f(t)|^p dt)^{\frac{1}{p}} < \infty$ and $\sup_{t \in A} |f(t)| < \infty$ for $p = \infty$

II. PROBLEM FORMULATION

We consider the controlled linear dynamical systems described by

$$\mathcal{G} : \begin{cases} \dot{x} = Ax + Bu + Gw, \\ y = Cx, \end{cases} \quad (1)$$

where, $x \in \mathcal{X} \subseteq \mathbb{R}^n$ are the states of the system, $y \in \mathcal{Y} \subseteq \mathbb{R}^{n_y}$ are the outputs of the system, $w \in \mathcal{W} \subseteq \mathbb{R}^{n_w}$ are the exogenous disturbances and $u \in \mathcal{U} \subseteq \mathbb{R}^m$ are the control signals. The matrices $A : \mathbb{R}^{n \times n}$, $B \in \mathbb{R}^{n \times m}$, $G \in \mathbb{R}^{n \times n_w}$ and $C \in \mathbb{R}^{n_y \times n}$.

We consider interconnected systems as illustrated in Fig. 1, where the subsystems $\{\mathcal{G}_i\}_{i=1}^N$ are known and have dynamics in the form of (1). We associate each subsystem with a set of matrices $\{A_i, B_i, G_i, C_i\}$ and $x_i \in \mathcal{X}_i \subseteq \mathbb{R}^{n_i}$, $w_i \in \mathcal{W}_i \subseteq \mathbb{R}^{n_w^i}$ and $y_i \in \mathcal{Y}_i \subseteq \mathbb{R}^{n_y^i}$. The static interconnection is characterized by a matrix $M \in \mathbb{R}^{n_w \times n_y}$ where $n = \sum_{i=1}^N n_i$, $n_w = \sum_{i=1}^N n_w^i$ and $n_y = \sum_{i=1}^N n_y^i$. That is, M satisfies

$$\begin{bmatrix} w \\ z \end{bmatrix} = M \begin{bmatrix} y \\ d \end{bmatrix}, \quad (2)$$

where $d \in \mathbb{R}^{n_d}$ and $z \in \mathbb{R}^{n_z}$. We assume this interconnection is well-posed, i.e., for all $d \in L_{2e}$ and initial condition $x(0) \in \mathbb{R}^n$, there exist unique $z, w, y \in L_{2e}$ that casually depend on d . Furthermore, we define

$$M = \begin{bmatrix} M_{wy} & M_{wd} \\ M_{zy} & M_{zd} \end{bmatrix},$$

where $M_{wy} \in \mathbb{R}^{n_w \times n_y}$, $M_{wd} \in \mathbb{R}^{n_w \times n_d}$, $M_{zy} \in \mathbb{R}^{n_z \times n_y}$, and $M_{zd} \in \mathbb{R}^{n_z \times n_d}$

The local and global supply rates, $W_i(w_i, y_i)$ and $W(d, z)$, respectively, are defined by quadratic functions. That is,

$$W(x, d, z) = \begin{bmatrix} d \\ z \end{bmatrix}' S \begin{bmatrix} d \\ z \end{bmatrix}. \quad (3)$$

In [16], the authors, inspired by the work [15], showed that certifying the dissipativity of an overall interconnected system can be concluded if each of the subsystems satisfy the local dissipativity property. Let

$$\mathcal{L}_i = \left\{ S_i \mid \begin{bmatrix} w_i \\ y_i \end{bmatrix}' S_i \begin{bmatrix} w_i \\ y_i \end{bmatrix} \leq 0 \right\}, \quad (4)$$

and

$$\mathcal{L} = \left\{ \{S_i\}_{i=1}^N \mid \begin{bmatrix} M \\ I_{n_y} \end{bmatrix}' P'_\pi Q P_\pi \begin{bmatrix} M \\ I_{n_y} \end{bmatrix} < 0 \right\}, \quad (5)$$

where $Q = \text{diag}(S_1, \dots, S_N, -S)$ and P_π is a permutation matrix defined by

$$\begin{bmatrix} w_1 \\ y_1 \\ \vdots \\ w_N \\ y_N \\ d \\ z \end{bmatrix} = P_\pi \begin{bmatrix} w \\ z \\ y \\ d \\ z \end{bmatrix}. \quad (6)$$

Proposition 1 (Proposition 1, [16]): Consider the interconnection of N subsystems as given in (2) with the global supply rate (3). If there exists $\{S_i\}_{i=1}^N$ satisfying

$$S_i \in \mathcal{L}_i, \quad i = 1, \dots, N, \quad (7)$$

and

$$(S_1, \dots, S_N, -S) \in \mathcal{L}, \quad (8)$$

then the interconnected system is dissipative with respect to the global supply rate. A storage function certifying global dissipativity is $V(x) = \sum_{i=1}^N V_i(x_i)$, where V_i is the storage function certifying dissipativity of subsystem i as in \mathcal{L}_i .

III. DISTRIBUTED SYNTHESIS USING DISSIPATIVITY

The dynamics of each subsystem of \mathcal{G} is characterized by

$$\mathcal{G}_i : \begin{cases} \dot{x}_i = A_i x_i + B_i u_i + G_i w_i, \\ y_i = C_i x_i, \end{cases} \quad (9)$$

with $i = 1, 2, \dots, N$. Using (2), the overall system can be described as

$$\mathcal{G} : \begin{cases} \dot{x} = (A + GM_{wy}C) x + Bu + M_{wd} d, \\ z = M_{zy}C x + M_{zd} d, \end{cases} \quad (10)$$

where $A = \text{diag}(A_1, \dots, A_N) \in \mathbb{R}^{n \times n}$, $B = \text{diag}(B_1, \dots, B_N) \in \mathbb{R}^{n \times n_u}$, $G = \text{diag}(G_1, \dots, G_N) \in \mathbb{R}^{n \times n_w}$ and $C = \text{diag}(C_1, \dots, C_N) \in \mathbb{R}^{n_y \times n}$. Although A has a block-diagonal structure, the overall system matrix $A + GM_{wy}C$ does not necessarily has any special sparsity

pattern or structure. Moreover, the controller takes the form of

$$u = Kx,$$

where $K = \text{diag}(K_1, \dots, K_N) \in \mathbb{R}^{n_u \times n}$. Therefore, K has a sparsity pattern inherited from the topology of the interconnections. In other words, for any subsystem \mathcal{G}_i , the local controllers have only access to the states x_i of the local subsystem.

In the following, we formulate conditions based on linear matrix inequalities to synthesize stabilizing and robust feedback controllers $u_i = K_i x_i$ for the subsystem (9) such that the overall system satisfies some dissipative property. The performance of these local controllers are certified by local storage functions $V(x_i) = x_i' P_i x_i$, $i = 1, 2, \dots, N$ based on Proposition 1.

A. Distributed Synthesis of Stabilizing Controllers

The following result states that the distributed search for a set of stabilizing controllers is a convex problem. Before we state the theorem, we define

$$S_i = \left[\begin{array}{c|c} S_i^{11} & S_i^{12} \\ \hline S_i^{21} & S_i^{22} \end{array} \right], \quad (11)$$

where $S_i^{11} \in \mathbb{S}^{n_w}$, $S_i^{12} \in \mathbb{R}^{n_w \times n_y}$, $S_i^{21} \in \mathbb{R}^{n_y \times n_w}$ and $S_i^{22} \in \mathbb{S}^{n_y}$.

Theorem 1: Consider subsystems (9) and the interconnection topology given by (2), with $d, z \equiv 0$. If there exist families of matrices $\{S_i\}_{i=1}^N$, $\{P_i\}_{i=1}^N$ ($P_i \in \mathbb{S}^{n_i}$) and $\{Y_i\}_{i=1}^N$ ($Y_i \in \mathbb{R}^{n_i \times n_i}$) such that (8) is satisfied with $S = 0$, and

$$P_i > 0, \quad i = 1, 2, \dots, N, \quad (12)$$

$$\left[\begin{array}{c} A_i' P_i + P_i A_i + Y_i' + Y_i - C_i' S_i^{22} C_i \\ G_i' P_i - S_i^{12} C_i \\ P_i G_i - C_i S_i^{21} \\ -S_i^{11} \end{array} \right] \leq 0, \quad (13)$$

for $i = 1, 2, \dots, N$, then the local controllers

$$K_i = B_i^\dagger P_i^{-1} Y_i, \quad (14)$$

render the overall system asymptotically stable.

Proof: Let $V_i(x) = x_i' P_i x_i$, $i = 1, 2, \dots, N$ be a family of local candidate storage functions. Inequalities (12) ensures that V_i 's are positive definite functions of x_i . Computing the time derivative of V_i gives

$$\frac{dV_i}{dt} = \dot{x}_i' P_i x_i + x_i' P_i \dot{x}_i.$$

Substituting (9) and $u_i = K_i x_i$ yields

$$\begin{aligned} \frac{dV_i}{dt} &= (A_i x_i + B_i K_i x_i + G_i w_i)' P_i x_i \\ &\quad + x_i' P_i (A_i x_i + B_i K_i x_i + G_i w_i) \\ &= x_i' (A_i' P_i + P_i A_i + K_i' B_i' P_i + P_i B_i K_i) x_i \\ &\quad + w_i' G_i' P_i x_i + x_i' P_i G_i w_i. \end{aligned}$$

Writing the last line of the above expression in quadratic form and substituting (14) gives

$$\frac{dV_i}{dt} = \begin{bmatrix} x_i \\ w_i \end{bmatrix}' \begin{bmatrix} A_i' P_i + P_i A_i + Y_i' + Y_i & P_i G_i \\ G_i' P_i & 0 \end{bmatrix} \begin{bmatrix} x_i \\ w_i \end{bmatrix} \quad (15)$$

Since (13) holds, if we multiply it left and right by $\begin{bmatrix} x_i \\ w_i \end{bmatrix}'$ and $\begin{bmatrix} x_i \\ w_i \end{bmatrix}$, respectively, we obtain

$$\frac{dV_i}{dt} \leq \begin{bmatrix} w_i \\ C_i x \end{bmatrix}' \begin{bmatrix} S_i^{11} & S_i^{12} \\ \hline S_i^{21} & S_i^{22} \end{bmatrix} \begin{bmatrix} w_i \\ C_i x \end{bmatrix}, \quad (16)$$

in which we used (15). Summing up the terms in the above expression for all i gives

$$\frac{dV}{dt} \leq \sum_{i=1}^N \begin{bmatrix} w_i \\ y_i \end{bmatrix}' S_i \begin{bmatrix} w_i \\ y_i \end{bmatrix}. \quad (17)$$

Furthermore, since (8) holds with $S = 0$, multiplying the LMI in (5) from left and right by $\begin{bmatrix} y \\ d \end{bmatrix}'$ and $\begin{bmatrix} y \\ d \end{bmatrix}$, respectively, and using the interconnection topology relation (2), we have

$$\sum_{i=1}^N \begin{bmatrix} w_i \\ y_i \end{bmatrix}' S_i \begin{bmatrix} w_i \\ y_i \end{bmatrix} < 0.$$

Therefore, $\frac{dV}{dt} \leq \sum_{i=1}^N \begin{bmatrix} w_i \\ y_i \end{bmatrix}' S_i \begin{bmatrix} w_i \\ y_i \end{bmatrix} < 0$. \blacksquare

B. Distributed H_∞ -Synthesis

Theorem 1 brings forward conditions under which the interconnected system can be stabilized by synthesizing a set of local controllers $\{K_i\}_{i=1}^N$. Depending on the choice of matrix Q , in particular S , in the global dissipativity constraint (5), we can have different synthesis performances. The next proposition states that we can synthesize local controllers such that the global H_∞ -norm from the inputs d to z is minimized.

Assumption 1 (Zero-State Detectability): Let $n_y < n$. It holds that

$$\text{rank} \left(M_{zy} \begin{bmatrix} C_1 & 0 & 0 \\ 0 & \ddots & 0 \\ 0 & 0 & C_N \end{bmatrix} \right) = n_y.$$

Note that the above assumption means that $y \equiv 0$ implies $x \equiv 0$. This property will be used in the Proposition below to prove asymptotic stability.

Proposition 2: Consider subsystems (9) and the interconnection topology given by (2). Let Assumption 1 holds and $d \in L_2$. If there exists a positive constant η , and families of matrices $\{S_i\}_{i=1}^N$, $\{P_i\}_{i=1}^N$ ($P_i \in \mathbb{S}^{n_i}$) and $\{Y_i\}_{i=1}^N$ ($Y_i \in \mathbb{R}^{n_i \times n_i}$) that solves the following optimization problem

$$\begin{aligned} &\min_{\{S_i\}_{i=1}^N, \{P_i\}_{i=1}^N, \{Y_i\}_{i=1}^N} \eta \\ &\text{subject to (12), (13), and (8)} \end{aligned} \quad (18)$$

with

$$S = \begin{bmatrix} \eta I_{n_d} & 0 \\ 0 & -I_{n_z} \end{bmatrix}, \quad (19)$$

then, the local controllers (14) render the interconnected system asymptotically stable for $d \equiv 0$. Furthermore, when $x(0) = 0$, we have

$$\|G\|_{\mathbf{H}_\infty} := \inf_{\|d\|_{L_2} \neq 0} \frac{\|z\|_{L_2}}{\|d\|_{L_2}} = \sqrt{\eta}. \quad (20)$$

Proof: The proof follows the same lines as the proof of Theorem 1. Since (8) holds with S given by (19), multiplying the LMI in (5) from left and right by $\begin{bmatrix} y \\ d \end{bmatrix}'$ and $\begin{bmatrix} y \\ d \end{bmatrix}$, respectively, and using the interconnection topology relation (2), we obtain

$$\sum_{i=1}^N \begin{bmatrix} w_i \\ y_i \end{bmatrix}' S_i \begin{bmatrix} w_i \\ y_i \end{bmatrix} < \begin{bmatrix} d \\ z \end{bmatrix}' \begin{bmatrix} \eta I_{n_d} & 0 \\ 0 & -I_{n_z} \end{bmatrix} \begin{bmatrix} d \\ z \end{bmatrix}.$$

From (13) and then (17), we have

$$\frac{dV}{dt} < \eta |d|^2 - |z|^2. \quad (21)$$

If $d \equiv 0$, we obtain

$$\frac{dV}{dt} < -|z|^2.$$

From Assumption 1, we infer that $|z|^2 = 0$ if and only if $x \equiv 0$. Thus, from LaSalle's Invariance Theorem [28], we deduce that the system is asymptotically stable.

Moreover, integrating both sides of inequality (21) from time 0 to ∞ gives

$$V(x(\infty)) - V(x(0)) < \eta \int_0^\infty |d(t)|^2 dt - \int_0^\infty |z(t)|^2 dt.$$

From the fact that the storage function is positive definite (it is the finite sum of positive definite functions), we infer that, for $x(0) \equiv 0$, $V(x(0)) = 0$ and we have

$$0 < \eta \int_0^\infty |d(t)|^2 dt - \int_0^\infty |z(t)|^2 dt.$$

That is,

$$\|z\|_{L_2}^2 < \eta \|d\|_{L_2}^2.$$

Hence, minimization over η gives (20). \blacksquare

The formulation presented here can also be extended to accommodate class of uncertainties and nonlinearities captured by Integral Quadratic Constraints (see Appendix).

C. Discussion on Conservativeness

In the following, we briefly discuss the conservativeness of the proposed method in Section III-A and Section III-B.

Given the subsystems $\mathcal{G}_1, \dots, \mathcal{G}_N$, the global Lyapunov function satisfies

$$V(x) = \sum_{i=1}^N V_i(x_i) = \begin{bmatrix} x_1 \\ \vdots \\ x_N \end{bmatrix}' \begin{bmatrix} P_1 & 0 & 0 \\ 0 & \ddots & 0 \\ 0 & 0 & P_N \end{bmatrix} \begin{bmatrix} x_1 \\ \vdots \\ x_N \end{bmatrix}.$$

This is indeed a conservative structure, since the cross terms in the quadratic Lyapunov function are zero. In fact, Theorem 1 searches over all *block-diagonal Lyapunov functions* in a distributed manner using dissipativity theory. Block-diagonal Lyapunov functions were also considered in [29] to design local controllers based on chordal decomposition techniques for block-chordal sparse matrices. In addition, it was demonstrated in [30], that block-diagonal Lyapunov functions lead to sparsity invariance and can be used design structured controllers.

Although converse theorems for diagonal Lyapunov functions have received tremendous attention in the literature (especially for positive systems [31], [32]), studies on finding the class of stable systems that admit block-diagonal Lyapunov functions are relatively few and far between [33]. Recently, in [34], the authors define a suitable comparison matrix, and then demonstrate that if the comparison matrix is scaled diagonal dominant, the stability of a block system is equivalent to the existence of a block diagonal Lyapunov function.

IV. COMPUTATIONAL FORMULATION USING ACCELERATED ADMM

For small-scale systems, we can solve the feasibility and optimization problems in Theorem 1 and Proposition 2 using publicly available SDP solvers like MOSEK [35], SeDuMi [36] or SDPT3 [37]. But, these SDP solvers do not scale well for larger problems. For larger problems, the ADMM algorithm [17] allows us to decompose convex optimization problems into a set of smaller problems. A generic convex optimization problem

$$\begin{aligned} & \text{minimize} && f(y) \\ & \text{subject to} && y \in C, \end{aligned} \quad (22)$$

where $x \in \mathbb{R}^n$, f is a convex function, and C is a convex set, can be written in ADMM form as

$$\begin{aligned} & \text{minimize} && f(y) + g(v) \\ & \text{subject to} && y = v, \end{aligned} \quad (23)$$

where g is the indicator function of C .

Using the above form, problem (8) can be written in ADMM form with $f(y)$ is defined as sum of μ and the indicator function of (12) and (13), and $g(v)$ is defined as the indicator function of (8). Then, the scaled form of ADMM form for problem in (23) is

$$\begin{aligned} y^{k+1} &= \arg \min_{y_i \in \mathcal{L}_i} f(y) + (\rho/2) \|y - v^k + u^k\|_2^2, \\ v^{k+1} &= \arg \min_{v \in \mathcal{C}} g(v) + (\rho/2) \|y^{k+1} - v + u^k\|_2^2, \\ u^{k+1} &= u^k + y^{k+1} - v^{k+1}, \end{aligned}$$

where y and v are the vectorized form of the matrices $\{S_i\}_{i=1}^N, \{P_i\}_{i=1}^N, \{Y_i\}_{i=1}^N$, u is the scaled dual variable and $\rho > 0$ is the *penalty parameter*. Since $f(y)$ is separable for

each subsystem, the ADMM algorithm can be parallelized as follows:

$$\begin{aligned} y_i^{k+1} &= \arg \min_{y_i \in \mathcal{L}_i} f_i(y) + (\rho/2) \|y_i - v_i^k + u_i^k\|_2^2, \\ v^{k+1} &= \arg \min_{v \in \mathcal{L}} g(v) + (\rho/2) \|y^{k+1} - v + u^k\|_2^2, \\ u^{k+1} &= u^k + y^{k+1} - v^{k+1}, \end{aligned}$$

Under mild assumptions, the ADMM algorithm converges [17], but the convergence is only asymptotic, therefore it may require many iterations to achieve sufficient accuracy.

A. Accelerated ADMM

For faster convergence, the so-called *accelerated* versions of similar first order algorithms have been proposed in the literature [18], [19], [20], [21], [22], and the methods achieve $O(\frac{1}{k^2})$ convergence after k iterations, which is shown to be optimal for a first order method [23]. The main drawback of these approaches is, they usually require the function $f(y)$ to be differentiable with a known Lipschitz constant on the $\nabla f(y)$, which does not exist when the problem has constraints. For the case when $f(y)$ or $g(y)$ is not strongly convex or smooth, smoothing approaches have been used [24], [25] to improve convergence. However, to the best of our knowledge, these methods have not been applied in distributed controller synthesis problems.

Consider the following perturbation of (18):

$$\begin{aligned} \min_{\{S_i\}_{i=1}^N, \{P_i\}_{i=1}^N, \{Y_i\}_{i=1}^N} \quad & \eta + \mu \sum_{i=1}^N d_i(S_i, P_i, Y_i) \\ \text{subject to} \quad & (12), (13), \text{ and } (8) \end{aligned} \quad (24)$$

for some fixed smoothing parameter $\mu > 0$ and a strongly convex function d that satisfies

$$d(y) \geq d(y_0) + \frac{1}{2} \|y - y_0\|_2^2 \quad (25)$$

for some point $y_0 \in \mathbb{R}^n$. Specifically, we choose $d_i = \|S_i\|_F + \|P_i\|_F + \|Y_i\|_F$, where $\|\cdot\|_F$ is the Frobenius norm. For some problems, it is shown that for small enough μ , the approximate problem (24) is equivalent to the original problem (18) [25].

When $f(x)$ and $g(x)$ are strongly convex, the ADMM algorithm can be modified with an acceleration step to achieve $O(\frac{1}{k^2})$ convergence after k iterations [26]. Then, the accelerated ADMM algorithm is

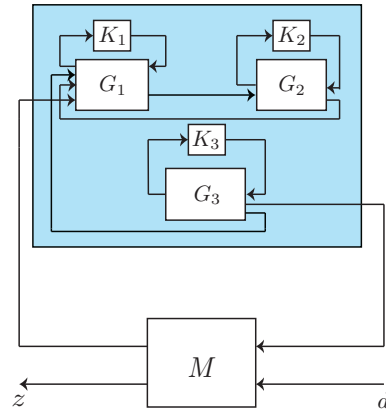

Fig. 2: The interconnected system in Example I.

$$\begin{aligned} y_i^k &= \arg \min_{y_i \in \mathcal{L}_i} f_i(y) + (\rho/2) \|y_i - \bar{v}_i^k + \bar{u}_i^k\|_2^2, \\ v^k &= \arg \min_{v \in \mathcal{L}} g(v) + (\rho/2) \|y^k - v + \bar{u}^k\|_2^2, \\ u^k &= \bar{u}^k + y^k - v^k, \\ \alpha_{k+1} &= \frac{1 + \sqrt{1 + 4\alpha_k^2}}{2} \\ \bar{v}^{k+1} &= v^k + \frac{\alpha_k - 1}{\alpha_{k+1}} (v^k - v^{k-1}) \\ \bar{u}^{k+1} &= u^k + \frac{\alpha_k - 1}{\alpha_{k+1}} (u^k - u^{k-1}), \end{aligned}$$

where ρ is a positive constant that satisfies $\rho \leq \mu$, and $\alpha_1 = 1$.

Note that y update can be carried out in parallel, while achieving $O(\frac{1}{k^2})$ convergence, which cannot be achieved by the standard ADMM or accelerated proximal methods due to constraints in the problem.

V. NUMERICAL EXPERIMENTS

In this section, we illustrate the proposed distributed synthesis method using two example. The first one is an average-sized system for which we present the constructed controllers and certificates. The second example pertains to a system with 100-states, where we compare the convergence rate of ADMM with accelerated ADMM. We implemented both standard ADMM and accelerated ADMM algorithms in MATLAB using the CVX toolbox [38] and MOSEK [35] to solve SDP problems.

A. Example I

We consider a modified version of the example in [39] as illustrated in Fig 2. For $i = 1, 2, 3$, the subsystems \mathcal{G}_i are characterized as follows:

$$\mathcal{G}_1 : \begin{cases} \dot{x}_1 = \begin{bmatrix} 4 & 0 \\ 2 & -2 \end{bmatrix} x_1 + I_2 \begin{bmatrix} w_2 \\ w_4 + d \end{bmatrix} + I_2 u_1, \\ w_1 = 0.5 \begin{bmatrix} 1 & 1 \end{bmatrix} x_1, \end{cases}$$

$$\mathcal{G}_2 : \begin{cases} \dot{x}_2 = \begin{bmatrix} 8 & 0 \\ 12 & -2 \end{bmatrix} x_2 + \begin{bmatrix} 1 \\ 1 \end{bmatrix} w_1 + I_2 u_2, \\ \begin{bmatrix} w_2 \\ w_3 \end{bmatrix} = 0.5 I_2 x_2, \end{cases}$$

$$\mathcal{G}_3 : \begin{cases} \dot{x}_3 = \begin{bmatrix} 2 & 0 \\ 2 & -2 \end{bmatrix} x_3 + \begin{bmatrix} 1 \\ 1 \end{bmatrix} w_3 + I_2 u_3, \\ w_3 = 0.4 \begin{bmatrix} 1 & 1 \end{bmatrix} x_3. \end{cases}$$

The global input and output are given as

$$d = \begin{bmatrix} 0 & 1 \end{bmatrix} x_3 \quad \text{and} \quad z = w_4 = 0.4 \begin{bmatrix} 1 & 1 \end{bmatrix} x_3.$$

The overall system with zero-input has 3 eigenvalues with positive real parts, therefore the zero-input system is unstable. We apply the compositional approach underlined by the problem in (24) to synthesize a controller to minimize the H_∞ -norm between the output z and input of d subsystem 1. After 19 iterations with the accelerated ADMM method, the value of the objective is $\eta = 4.9 \cdot 10^{-4}$ with the following controllers:

$$K_1 = \begin{bmatrix} -4.7760 & -1.1078 \\ -1.1138 & -0.6947 \end{bmatrix},$$

$$K_2 = \begin{bmatrix} -6.5288 & -4.5095 \\ -5.5751 & -3.8507 \end{bmatrix},$$

$$K_3 = \begin{bmatrix} -100.4125 & -90.2510 \\ -56.2576 & -50.5649 \end{bmatrix}.$$

and following local Lyapunov functions:

$$P_1 = \begin{bmatrix} 0.001 & -2.7 \cdot 10^{-6} \\ -2.7 \cdot 10^{-9} & 0.0010 \end{bmatrix},$$

$$P_2 = \begin{bmatrix} 0.0019 & -9.87 \cdot 10^{-4} \\ -9.87 \cdot 10^{-4} & 0.0021 \end{bmatrix},$$

$$P_3 = \begin{bmatrix} 0.0045 & -0.0064 \\ -0.0064 & 0.0129 \end{bmatrix}.$$

B. Example II

In order to test and compare the different forms of ADMM methods discussed in Section IV, we randomly generated $N = 20$ unstable and controllable LTI subsystems, each with 5 states, 2 inputs, and 2 outputs. The dynamics of each subsystem is characterized by the equations (9), with the maximum real part for an eigenvalue of A_i is normalized to 1, and random interconnection matrix M that was randomly generated with 5% its entries being nonzero.

The iterative methods were initialized using $S_i^0 = P_i^0 = Y_i^0 = U_i^0 = I$. For each method, we plot the norm of *primal residual* in Figure 3, which is defined as $r^k = x^k - x^k$, and it is the residual for primal feasibility. Also, we show the norm of the *dual residual* $s^k = \rho(z^k - z^{k-1})$ in Figure 4, which can be viewed as a residual for the dual feasibility condition.

We remark that the accelerated ADMM method significantly improves the convergence rate for primal and dual

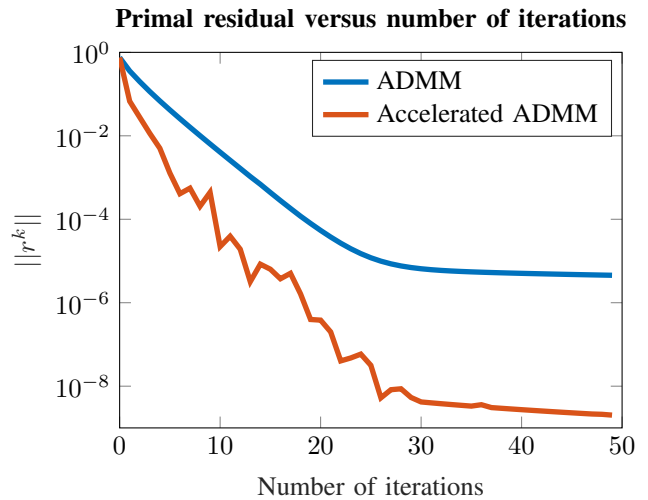

Fig. 3: Norm of primal residual versus number of iterations for the decentralized synthesis problem with standard and accelerated ADMM.

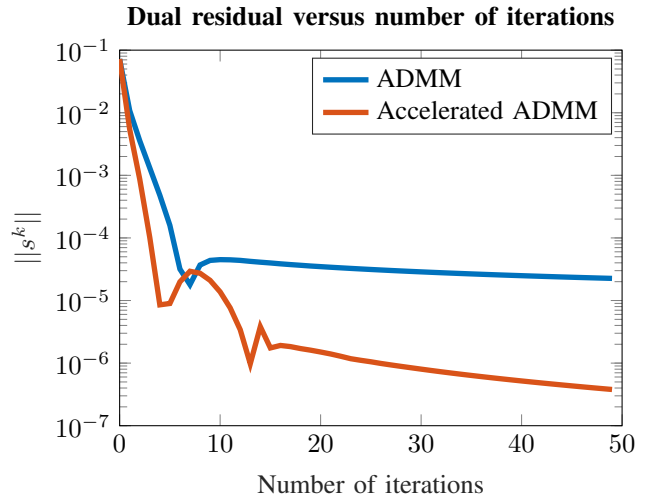

Fig. 4: Norm of dual residual versus number of iterations for the decentralized synthesis problem with standard and accelerated ADMM.

residuals compared to standard ADMM. After 20 iterations, the accelerated method achieves convergence within the tolerance $\epsilon = 10^{-6}$, which is not achievable by the standard ADMM method after 50 iterations, and it may require many iterations for the standard ADMM method to achieve high accuracy.

VI. CONCLUSIONS AND FUTURE WORK

We studied the distributed synthesis problem of large scale linear systems, for which an underlying interconnection topology is given. For such systems, we decompose the structured controller design problem (inherited by the interconnection topology) into a number of smaller local synthesis problems associated with local dissipation inequalities and a global gain condition. Furthermore, we proposed a distributed optimization method with smoothing techniques,

which enables to employ accelerated ADMM. Numerical results show that the accelerated ADMM method significantly improves the convergence rate compared to standard ADMM. As discussed in Section III-C, the block-diagonal Lyapunov function structure may lead to some degree of conservatism. Future research will explore other Lyapunov function structures that are less conservative and, at the same time, lead to a decompositional synthesis technique. In particular, the vector Lyapunov approach [40] seems promising in this respect. Future research will also consider the extensions of the distributed synthesis method to nonlinear (polynomial) systems and hybrid dynamical systems.

REFERENCES

- [1] T. P. Prescott and A. Papachristodoulou, "Layered decomposition for the model order reduction of timescale separated biochemical reaction networks," *Journal of Theoretical Biology*, vol. 356, pp. 113 – 122, 2014.
- [2] F. Dorfler, M. R. Jovanovic, M. Chertkov, and F. Bullo, "Sparsity-promoting optimal wide-area control of power networks," *IEEE Transactions on Power Systems*, vol. 29, no. 5, pp. 2281–2291, 2014.
- [3] G. Dullerud and F. Paganini, *A Course in Robust Control Theory: A Convex Approach*, ser. Texts in Applied Mathematics. Springer New York, 2005.
- [4] V. Blondel and J. N. Tsitsiklis, "NP-hardness of some linear control design problems," *SIAM Journal on Control and Optimization*, vol. 35, no. 6, pp. 2118–2127, 1997.
- [5] M. Rotkowitz and S. Lall, "A characterization of convex problems in decentralized control," *IEEE Transactions on Automatic Control*, vol. 50, no. 12, pp. 1984–1996, 2005.
- [6] J. H. Kim and S. Lall, "Explicit solutions to separable problems in optimal cooperative control," *IEEE Transactions on Automatic Control*, vol. 60, no. 5, pp. 1304–1319, 2015.
- [7] P. Shah and P. A. Parrilo, " h_2 -optimal decentralized control over posets: A state-space solution for state-feedback," *IEEE Transactions on Automatic Control*, vol. 58, no. 12, pp. 3084–3096, 2013.
- [8] K. Dvijotham, E. Todorov, and M. Fazel, "Convex structured controller design in finite horizon," *IEEE Transactions on Control of Network Systems*, vol. 2, no. 1, pp. 1–10, 2015.
- [9] G. Fazelnia, R. Madani, A. Kalbat, and J. Lavaei, "Convex relaxation for optimal distributed control problems," *IEEE Transactions on Automatic Control*, vol. 62, no. 1, pp. 206–221, 2017.
- [10] F. Lin, M. Fardad, and M. R. Jovanovic, "Design of optimal sparse feedback gains via the alternating direction method of multipliers," *IEEE Transactions on Automatic Control*, vol. 58, no. 9, pp. 2426–2431, 2013.
- [11] —, "Augmented lagrangian approach to design of structured optimal state feedback gains," *IEEE Transactions on Automatic Control*, vol. 56, no. 12, pp. 2923–2929, 2011.
- [12] J. C. Willems, "Dissipative dynamical systems part I: General theory," *Archive for rational mechanics and analysis*, vol. 45, no. 5, pp. 321–351, 1972.
- [13] J. Anderson and A. Papachristodoulou, "A decomposition technique for nonlinear dynamical system analysis," *IEEE Transactions on Automatic Control*, vol. 57, no. 6, pp. 1516–1521, 2012.
- [14] R. Pates and G. Vinnicombe, "Scalable design of heterogeneous networks," *IEEE Transactions on Automatic Control*, vol. 62, no. 5, pp. 2318–2333, 2017.
- [15] U. Topcu, A. K. Packard, and R. M. Murray, "Compositional stability analysis based on dual decomposition," in *Proceedings of the 48th IEEE Conference on Decision and Control (CDC) held jointly with 2009 28th Chinese Control Conference*, 2009, pp. 1175–1180.
- [16] C. Meissen, L. Lessard, M. Arcaç, and A. K. Packard, "Compositional performance certification of interconnected systems using ADMM," *Automatica*, vol. 61, pp. 55 – 63, 2015.
- [17] S. Boyd, N. Parikh, E. Chu, B. Peleato, and J. Eckstein, "Distributed optimization and statistical learning via the alternating direction method of multipliers," *Foundations and Trends® in Machine Learning*, vol. 3, no. 1, pp. 1–122, 2011.
- [18] E. T. Hale, W. Yin, and Y. Zhang, "Fixed-point continuation for ℓ_1 -minimization: Methodology and convergence," *SIAM Journal on Optimization*, vol. 19, no. 3, pp. 1107–1130, 2008.
- [19] S. Becker, J. Bobin, and E. J. Candès, "Nesta: A fast and accurate first-order method for sparse recovery," *SIAM Journal on Imaging Sciences*, vol. 4, no. 1, pp. 1–39, 2011.
- [20] Y. Nesterov, "Gradient methods for minimizing composite functions," *Mathematical Programming*, vol. 140, no. 1, pp. 125–161, 2013.
- [21] A. Beck and M. Teboulle, "A fast iterative shrinkage-thresholding algorithm for linear inverse problems," *SIAM journal on imaging sciences*, vol. 2, no. 1, pp. 183–202, 2009.
- [22] A. I. Chen and A. Ozdaglar, "A fast distributed proximal-gradient method," in *Communication, Control, and Computing (Allerton), 2012 50th Annual Allerton Conference on*. IEEE, 2012, pp. 601–608.
- [23] Y. Nesterov, "A method of solving a convex programming problem with convergence rate $o(\frac{1}{k^2})$," *Soviet Mathematics Doklady*, vol. 27, pp. 372–376.
- [24] —, "Smooth minimization of non-smooth functions," *Mathematical programming*, vol. 103, no. 1, pp. 127–152, 2005.
- [25] S. R. Becker, E. J. Candès, and M. C. Grant, "Templates for convex cone problems with applications to sparse signal recovery," *Mathematical programming computation*, vol. 3, no. 3, pp. 165–218, 2011.
- [26] T. Goldstein, B. O'Donoghue, S. Setzer, and R. Baraniuk, "Fast alternating direction optimization methods," *SIAM Journal on Imaging Sciences*, vol. 7, no. 3, pp. 1588–1623, 2014.
- [27] G. H. Golub and C. F. Van Loan, *Matrix Computations*. Baltimore, MD, USA: Johns Hopkins University Press, 1996.
- [28] H. K. Khalil, "Nonlinear systems," *Prentice-Hall, New Jersey*, vol. 2, no. 5, pp. 5–1, 1996.
- [29] Y. Zheng, R. P. Mason, and A. Papachristodoulou, "Scalable design of structured controllers using chordal decomposition," *IEEE Transactions on Automatic Control*, 2017.
- [30] Y. Zheng, M. Kamgarpour, A. Sootla, and A. Papachristodoulou, "Convex design of structured controllers using block-diagonal Lyapunov functions," *ArXiv*, preprint. [Online]. Available: <https://arxiv.org/abs/1709.00695>
- [31] A. Rantzer, "Scalable control of positive systems," *European Journal of Control*, vol. 24, pp. 72 – 80, 2015.
- [32] R. S. Varga, "On recurring theorems on diagonal dominance," *Linear Algebra and its Applications*, vol. 13, no. 1, pp. 1 – 9, 1976.
- [33] D. G. Feingold and R. S. Varga, "Block diagonally dominant matrices and generalizations of the Gerschgorin circle theorem," *Pacific J. Math.*, vol. 12, no. 4, pp. 1241–1250, 1962.
- [34] A. Sootla, Y. Zheng, and A. Papachristodoulou, "Block-diagonal solutions to Lyapunov inequalities and generalisations of diagonal dominance," in *2017 56th IEEE Conference on Decision and Control (CDC)*, 2017.
- [35] E. D. Andersen and K. D. Andersen, "The mosek optimization software," *EKA Consulting ApS, Denmark*, 2012.
- [36] J. F. Sturm, "Using sedumi 1.02, a matlab toolbox for optimization over symmetric cones," *Optimization methods and software*, vol. 11, no. 1-4, pp. 625–653, 1999.
- [37] K.-C. Toh, M. J. Todd, and R. H. Tütüncü, "Sdpt3, Āa matlab software package for semidefinite programming, version 1.3," *Optimization methods and software*, vol. 11, no. 1-4, pp. 545–581, 1999.
- [38] M. Grant and S. Boyd, "Cvx: Matlab software for disciplined convex programming."
- [39] U. Topcu, A. K. Packard, and R. M. Murray, "Compositional stability analysis based on dual decomposition," in *Decision and Control, 2009 held jointly with the 2009 28th Chinese Control Conference. CDC/CCC 2009. Proceedings of the 48th IEEE Conference on*. IEEE, 2009, pp. 1175–1180.
- [40] S. Kundu and M. Anghel, "Stability and control of power systems using vector Lyapunov functions and sum-of-squares methods," in *2015 European Control Conference (ECC)*, 2015, pp. 253–259.
- [41] A. Megretski and A. Rantzer, "System analysis via integral quadratic constraints," *IEEE Transactions on Automatic Control*, vol. 42, no. 6, pp. 819–830, 1997.
- [42] V. A. Yakubovich, "S-procedure in nonlinear control theory," *Vestnik Leningrad University: Mathematics*, vol. 1, pp. 62–77, 1971.
- [43] P. Seiler, "Stability analysis with dissipation inequalities and integral quadratic constraints," *IEEE Transactions on Automatic Control*, vol. 60, no. 6, pp. 1704–1709, 2015.

APPENDIX

In this section, we consider large-scale systems with subsystems that are subject to nonlinearities, time variations, and uncertain parameters which can be characterized by an integral quadratic constraint (IQC) [41], [42]. Let $\Gamma : j\mathbb{R} \rightarrow \mathbb{C}^{n_\mu \times n_\zeta}$ be a measurable Hermitian-valued function. We say Δ satisfies the IQC defined by Γ , if and only if the following inequality holds

$$\int_{-\infty}^{\infty} \begin{bmatrix} \hat{\mu}(j\omega) \\ \hat{\zeta}(j\omega) \end{bmatrix}' \Gamma(j\omega) \begin{bmatrix} \hat{\mu}(j\omega) \\ \hat{\zeta}(j\omega) \end{bmatrix} d\omega \geq 0, \quad (26)$$

where $\mu \in L_2$, $\zeta = \Delta(\mu)$, and $\hat{\mu}(j\omega)$ and $\hat{\zeta}(j\omega)$ are the Fourier transforms of μ and ζ , respectively. If the IQC multiplier Γ is uniformly bounded on the imaginary axis and rational, then (26) can also be described in the time-domain, wherein Γ can be factorized as $\Psi(j\omega)^* Q \Psi(j\omega)$, with Q being a constant matrix and Ψ being a stable linear time invariant system. Let Ψ have the realization

$$\Psi : \begin{cases} \dot{\gamma} = \tilde{A}\gamma + \tilde{B}\mu + \tilde{G}\zeta, \\ y_\psi = \tilde{C}\gamma + \tilde{D}\mu + \tilde{H}\zeta \\ \gamma(0) = 0. \end{cases} \quad (27)$$

Since our formulation is based on dissipation inequalities, we consider the so called "hard" IQCs [43] defined by (Ψ, Q) . That is, IQCs of the form

$$\int_0^T y_\psi' Q y_\psi dt \geq 0, \quad (28)$$

for any $0 \leq T < \infty$, y_ψ is defined as

$$y_\psi = \Psi \begin{bmatrix} \mu \\ \zeta \end{bmatrix}.$$

To account for IQC-bounded uncertainties, we consider local storage functions $V_i(x_i, \gamma_i) = \begin{bmatrix} x_i \\ \gamma_i \end{bmatrix}' P_i \begin{bmatrix} x_i \\ \gamma_i \end{bmatrix}$ with P_i of appropriate dimension depending on the realization of Ψ_i . Then, in order for the subsystems to be dissipative subject to an IQC, condition (7) should be modified to

$$\begin{aligned} & \left(\frac{\partial V_i}{\partial x_i} \right)' (A_i x_i + B_i u_i + G_i w_i) \\ & + \left(\frac{\partial V_i}{\partial \gamma_i} \right)' (\tilde{A}_i \gamma_i + \tilde{B}_i \mu_i + \tilde{G}_i \zeta_i) \leq \begin{bmatrix} w_i \\ y_i \end{bmatrix}' S_i \begin{bmatrix} w_i \\ y_i \end{bmatrix} \\ & - \lambda_i \left(\tilde{C}_i \gamma_i + \tilde{D}_i \mu_i + \tilde{H}_i \zeta_i \right)' Q_i \left(\tilde{C}_i \gamma_i + \tilde{D}_i \mu_i + \tilde{H}_i \zeta_i \right) \end{aligned} \quad (29)$$

for some $\lambda_i > 0$.

Then, Lemma 1 in [43] can be used to formulate LMI conditions for checking dissipativity of the subsystem subject to an uncertainty or nonlinearity defined by an IQC.